

Beam Luminaire Features

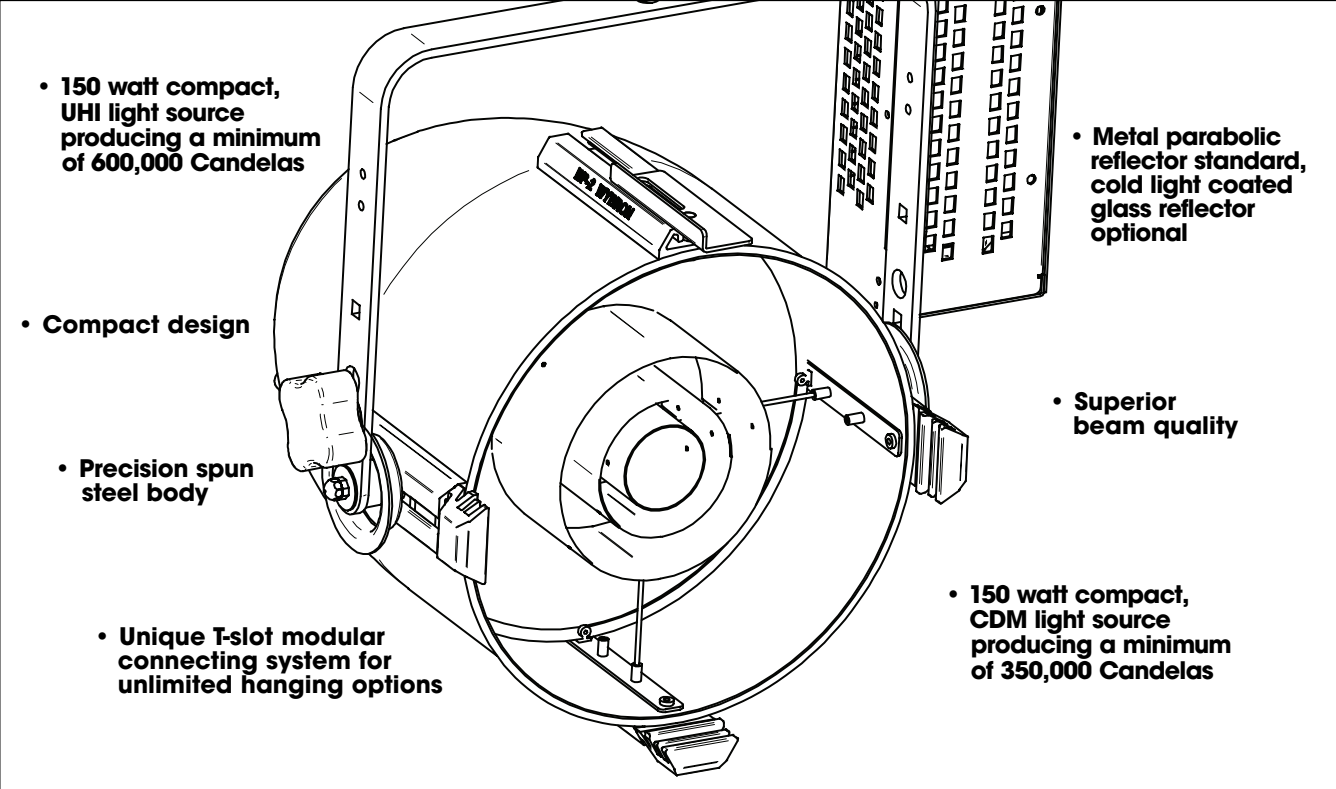

This compact, next generation beam projector uses the latest developments in optical and mechanical design, to give today's lighting designers another tool in their ever expanding arsenal of lighting effects. The BP-2 Beam Luminaire produces an extremely intense soft edge narrow 10°-13° beam (lamp dependent) of light several times more intense than an ordinary spotlight of similar wattage.

Built of rugged spun steel, with a metal parabolic reflector, it uses a high output, compact 150W CDM or UHI light source. Its unique T-slot modular connection system allows the designer to combine an unlimited number of BP-2s in any desired array to satisfy any lighting situation.

The BP-2 makes a statement by breaking through the atmosphere on a stage or used architecturally as a long-throw wash to light specific areas brilliantly. And the BP-2 is economical, easy-to-use and manufactured with Wybron's legendary reliability .

BP-2 Dimensions

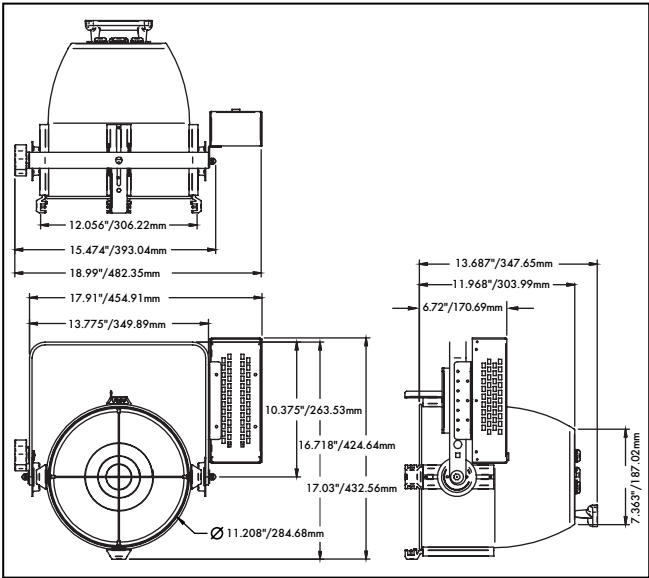

Physical

Housing: Precision spun, cold rolled 1mm steel housing

Yoke: Flat steel with two mounting positions

5/8" T-slot mounting rails every 90°

Accessories: Accepts up to two standard 12" accessories;
Standard spring-loaded safety latch

High impact, thermally insulating handle

Safety Cable: 3.5 ft./1.06m long cable included

Finish: High temperature black powder coat, other colors available, consult factory

Weight: 14.3 lbs. (6.5 kg)

Optical

Reflector: Parabolic metal

Concentric ring system to control light spill

Tempered safety glass lamp containment & UV blocker

Lamp

Socket: G12 style, rated to 350° C

Tool free precision lamp alignment

Electrical

Power Supply: Ballast voltage 120-277VAC

Cable: 36" Teflon coated leads encased in heat resistant black fiberglass sleeve

Accessories

Optional malleable iron pipe clamp

Optionally available with installed Stage pin, Twist lock & Edison connectors

Lamp Data

Lamp Model	CDM150T6830	UHI-S150DW/A/UVP
Lamp Watts(nominal)	150	150
Rated Lumens	14,000	13,000
Rated Hours	10,000	10,000
Color Temp	3000K	3000K
Color Rendering Index	85	80
Efficacy (Luminous Output)	93Lm/W	80Lm/W

Photometrics-150W CDM Lamp @ 115V

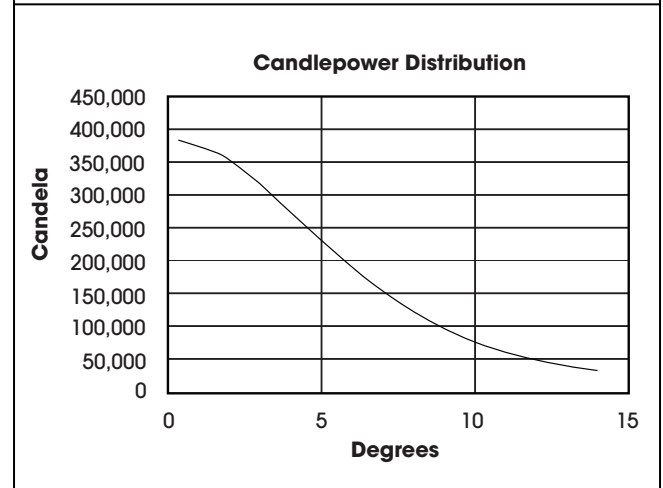
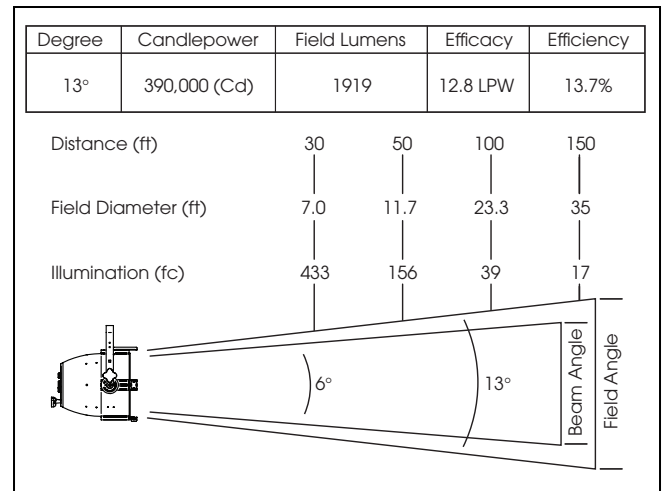

Specifications as of 3/5/05 and may be subject to change

Ordering Information

BP-2 Beam Luminaire	
Model	Description
9520	BP-2 Beam Luminaire CDM (metal reflector)
BP-2 Beam Luminaire Accessories	
256-08-21	Malleable Iron C-clamp
CDM150T6830	Lamp, CDM 150W w/UV Fade Block
UHI-S150DW/A/UVP	Lamp, UHI 150W
BP-2 AC Power Connectors	
S	Stage Pin Connector
T	Twist Lock Connector
E	Edison Connector